

FEC16 Extended Temperature Field Equipment Controller

Installation Instructions

MS-FEC1611-0ET

Part No. 24-10143-306, Rev. A

Release 6.0

Issued January 30, 2013

Supersedes January 26, 2012

Refer to the [QuickLIT website](#) for the most up-to-date version of this document.

Applications

The FEC16 extended temperature field controller is part of the Metasys® system Field Equipment Controller (FEC) family. The FEC16 controller runs pre-engineered and user-programmed applications and provides the inputs and outputs required to monitor and control a wide variety of Heating, Ventilating, and Air Conditioning (HVAC) equipment.

FEC extended temperature controllers operate on an RS-485 BACnet® Master-Slave/Token-Passing (MS/TP) Bus as BACnet Application Specific Controllers (B-ASCs) and integrate into the Web-based Metasys system.

IMPORTANT: In Metasys system smoke control applications, use only the MS-FEU1610-0U and MS-FEU1620-0U models that are UL Listed, UUKL 864 Listed, Smoke Control Equipment. For Metasys system smoke control applications, you must refer to the *Metasys System UL 864 UUKL Ninth Edition Smoke Control System Technical Bulletin (LIT-12011252)* for detailed requirements and procedures for installing and operating UUKL 864 Listed Metasys system devices. Failure to meet the requirements or follow the procedures in the *Metasys System UL 864 UUKL Ninth Edition Smoke Control System Technical Bulletin (LIT-12011252)* can void the UUKL 864 listing for Smoke Control Equipment.

North American Emissions Compliance

Canada

This Class (A) digital apparatus meets all the requirements of the Canadian Interference-Causing Equipment Regulations.

Cet appareil numérique de la Classe (A) respecte toutes les exigences du Règlement sur le matériel brouilleur du Canada.

United States

This equipment has been tested and found to comply with the limits for a Class A digital device pursuant to Part 15 of the FCC Rules. These limits are designed to provide reasonable protection against harmful interference when this equipment is operated in a commercial environment. This equipment generates, uses, and can radiate radio frequency energy and, if not installed and used in accordance with the instruction manual, may cause harmful interference to radio communications. Operation of this equipment in a residential area may cause harmful interference, in which case the users will be required to correct the interference at their own expense.

Installation

Observe these guidelines when installing an FEC extended temperature controller:

- Transport the FEC in the original container to minimize vibration and shock damage.
- Verify that all parts shipped with the FEC.
- Do not drop the FEC or subject it to physical shock.

Parts Included

- one FEC16 controller with removable terminal blocks
- one installation instructions sheet

Materials and Special Tools Needed

- three fasteners appropriate for the mounting surface (M4 screws or #8 screws)
- one 20 cm (8 in.) or longer piece of 35 mm DIN rail and appropriate hardware for DIN rail mount (only)
- small straight blade screwdriver for securing wires in the terminal blocks

Mounting

Observe these guidelines when mounting an FEC extended temperature controller:

- Ensure the mounting surface can support the FEC, DIN rail, and any user-supplied enclosure.
- Mount the FEC on 35 mm DIN rail whenever possible.
- Mount the FEC in the proper mounting position (Figure 1).
- Mount the FEC on a hard, even surface whenever possible in wall-mount applications.
- Use shims or washers to mount the FEC securely and evenly on the mounting surface.
- Mount the FEC in an area free of corrosive vapors and observe the Ambient Conditions in the *Technical Specifications* section.
- Provide for sufficient space around the FEC for cable and wire connections, easy cover removal, and good ventilation through the controller (50 mm [2 in.] minimum on the top, bottom, and front of the controllers).
- Do not mount the FEC on surfaces prone to vibration, such as duct work, or in areas where electromagnetic emissions from other devices or wiring can interfere with controller communication.

On panel or enclosure mount applications, observe these additional guidelines:

- Do not install the FEC in an airtight enclosure.
- Mount the FEC so that the enclosure walls do not obstruct cover removal or ventilation through the controller.
- Mount the FEC so that the power transformer and other devices do not radiate excessive heat to the controller.

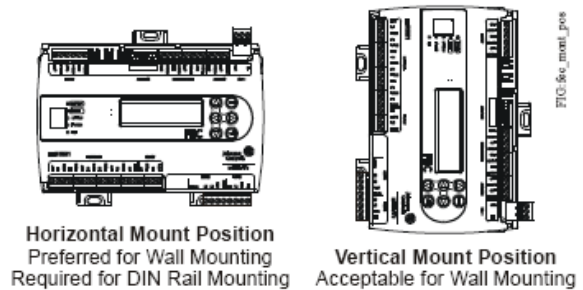

Figure 1: Controller Mounting Positions

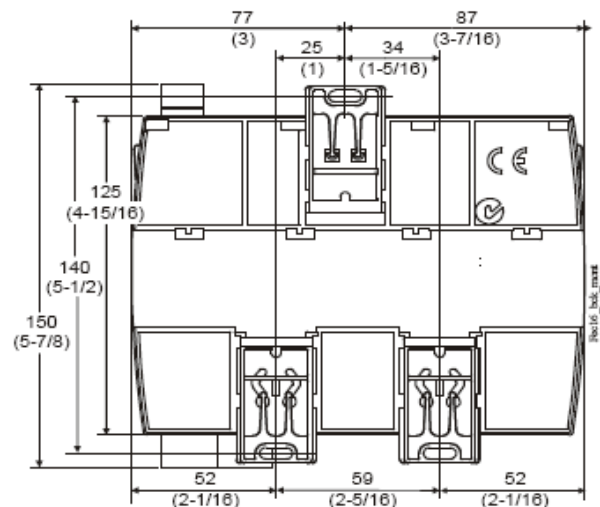

Figure 2: Back of FEC16 Controller Showing Extended Mounting Clips, DIN Rail Channel, and

DIN Rail Mount Applications

DIN rail mounting is the preferred mounting method. To mount an FEC on 35 mm DIN rail:

1. Securely mount a 20 cm (8 in.) or longer section of 35 mm DIN rail horizontal and centered in the desired space so that the controller mounts in the horizontal position shown in Figure 1.
2. Pull the two bottom mounting clips outward to the extended position (Figure 2).
3. Hang the controller on the DIN rail by the hooks at the top of the (DIN rail) channel on the back of the controller (Figure 2), and position the controller snugly against the DIN rail.
4. Push the bottom mounting clips inward to secure the controller on the DIN rail.

To remove the FEC from the DIN rail, pull the bottom mounting clips out to the extended position and carefully lift the controller off the DIN rail.

Wall Mount Applications

To mount an FEC directly on a wall (or other flat vertical surface):

1. Pull the two bottom mounting clips outward and ensure they are locked in the extended positions as shown in Figure 2.
2. Mark the three mounting hole locations on the wall using the dimensions in Figure 2 and one of the mount positions shown in Figure 1 (or hold the controller up to the wall/surface in a proper mount position and mark the hole locations through the mounting clips.)
3. Drill holes in the wall at the locations marked in Step 2, and insert appropriate wall anchors in all three holes (if necessary).
4. Hold the FEC in place, and insert the screws through the mounting clips and into the holes. Carefully tighten all of the screws.

IMPORTANT: Do not overtighten the mounting screws. Overtightening the screws may damage the mounting clips.

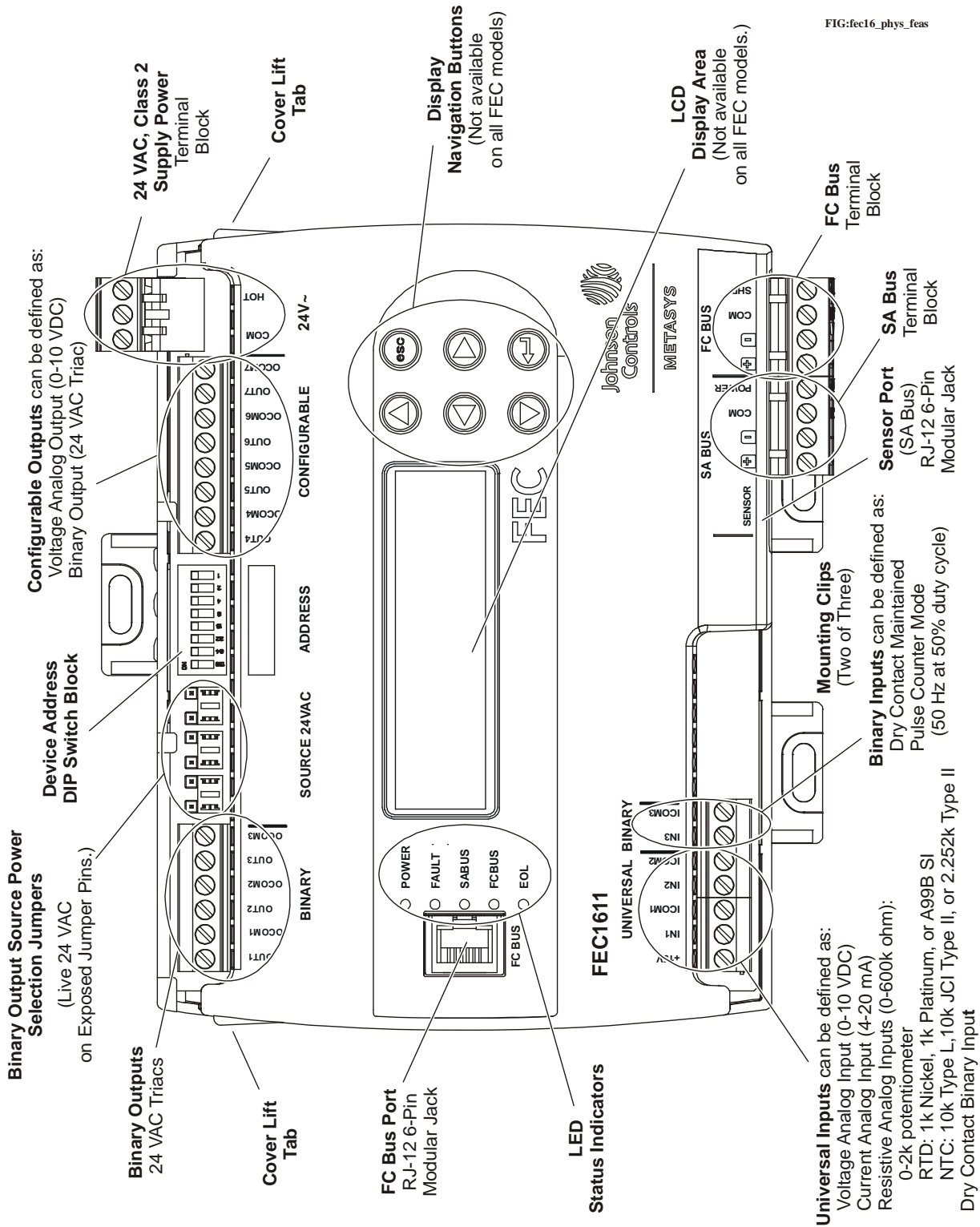

Figure 3: FEC1611 Controller Physical Features and Wiring Terminals

Wiring



CAUTION: Risk of Electric Shock.
Disconnect the power supply before making electrical connections to avoid electric shock.

IMPORTANT: Do not connect supply power to the controller before finishing wiring and checking all wiring connections. Short circuits or improperly connected wires can result in damage to the controller and void any warranty.

IMPORTANT: Do not exceed the controller electrical ratings. Exceeding controller electrical ratings can result in permanent damage to the controller and void any warranty.

IMPORTANT: Use copper conductors only. Make all wiring in accordance with local, national, and regional regulations.

IMPORTANT: Electrostatic discharge can damage controller components. Use proper electrostatic discharge precautions during installation, setup, and servicing to avoid damaging the controller.

For detailed information on configuring and wiring an MS/TP Bus, Field Controller (FC) Bus, and Sensor Actuator (SA) Bus, refer to the *MS/TP Communications Bus Technical Bulletin (LIT-12011034)*.

FEC Terminal Blocks and Bus Ports

See Figure 3 for terminal block and bus port locations on the FEC16 controller. Observe the following guidelines when wiring an FEC controller.

Input and Output Terminal Blocks

All of the fixed input terminal blocks are mounted on the bottom of the FEC. The output terminal blocks are mounted on the top of the controller. See Table 1 for more information.

FC Bus Terminal Block

The FC Bus terminal block is a blue, removable, 4-terminal plug that fits into a board-mounted jack.

Wire the removable FC Bus terminal block plugs on the FEC, and other field controllers in a daisy-chain configuration using 3-wire twisted, shielded cable as shown in Figure 4. See Table 3 for more information.

Note: The Shield terminal (SHLD) on the FC Bus terminal block is isolated and can be used to connect the cable shields on the bus (Figure 4).

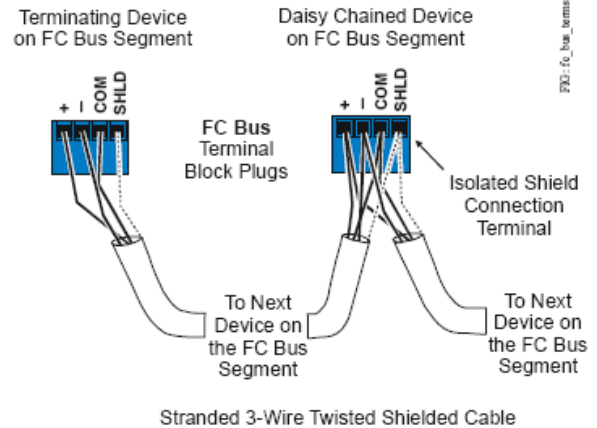

Figure 4: FC Bus Terminal Block Wiring

SA Bus Terminal Block

The SA Bus terminal block is a brown, removable, 4-terminal plug that fits into a board-mounted jack.

Wire the removable SA Bus terminal block plugs on the FEC and other SA Bus devices in a daisy-chain configuration using 4-wire twisted, shielded cable as shown in Figure 5. See Table 3 for more information.

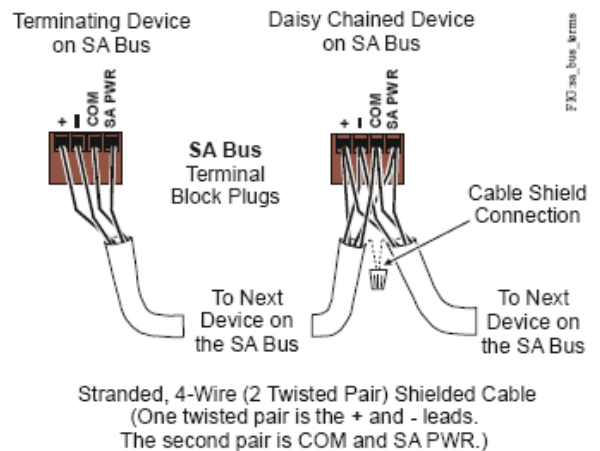

Figure 5: SA Bus Terminal Block Wiring

FC Bus Port

The FC Bus port on the front of the FEC is an RJ-12, 6-position modular jack that provides a connection for the Wireless Commissioning Converter or ZFR1811 Wireless Field Bus Router.

The FC Bus port is connected internally to the FC Bus terminal block. See Table 3 for more information. The FC Bus Port pin assignment is shown in Figure 6.

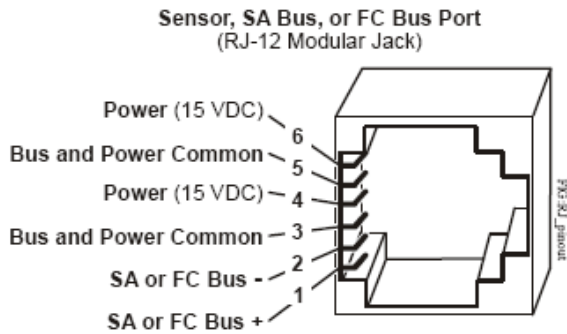

Figure 6: Pin Number Assignments for Sensor, SA Bus, and FC Bus Ports on FEC, IOM, and VMA16

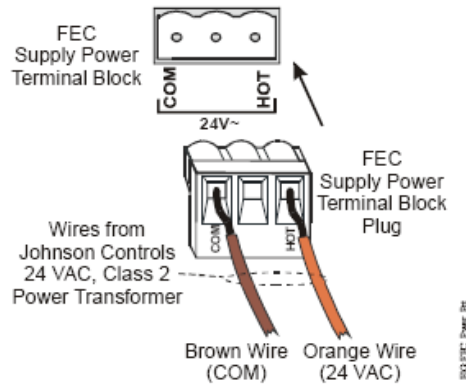

Figure 7: 24 VAC Supply Power Terminal Block Wiring

Sensor Port

The Sensor (SA Bus) port on the bottom of the FEC (Figure 3) is an RJ-12, 6-position modular jack that provides a connection for the Wireless Commissioning Converter, the VAV Balancing Tool, specified network sensors, or other SA Bus devices with RJ-12 plugs.

A DIS1710 Local Controller Display also can be connected to the SA Bus port (but only on FEC models without integral display and push buttons).

The Sensor port is connected internally to the SA Bus terminal block. See Table 3 for more information. The Sensor Port pin assignment is shown in Figure 6.

Supply Power Terminal Block

The 24 VAC supply power terminal block is a gray, removable, 3-terminal plug that fits into a board-mounted jack on the top right of the FEC.

Wire the 24 VAC supply power wires from the transformer to the HOT and COM terminals on the terminal plug as shown in Figure 7. The middle terminal on the supply power terminal block is not used. See Table 3 for more information.

The supply power wire colors may be different on transformers from other manufacturers. Refer to the transformer manufacturer's instructions and the project installation drawings for wiring details.

IMPORTANT: Connect 24 VAC supply power to the FEC and all other network devices so that transformer phasing is uniform across the network devices. Powering network devices with uniform 24 VAC supply power phasing reduces noise, interference, and ground loop problems. The FEC does not require an earth ground connection.

Wireless Network Applications

The FEC also can be installed in a wireless application. To configure a controller for use with the ZFR1800 Series Wireless Field Bus system:

1. Wire the input/output terminals and SA Bus.
 - Note:** In wireless network applications, do **not** connect any wires to the FC Bus terminal block.
2. Connect the ZFR1811 Wireless Field Bus Router to the FC Bus port (RJ-12 modular jack) on the front of the FEC.
3. Ensure that the FEC device address DIP switches are set to the correct device address. See [Setting the Device Address](#).
4. Position DIP switch 128 to ON to enable wireless operation on the FEC.

For more information on installing an FEC in a wireless configuration, refer to the *ZFR1811 Wireless Field Bus Router Installation Instructions (Part No. 24-10325-1)*.

FEC Terminal Functions, Ratings, Requirements, and Wiring Guidelines

Input and Output Wiring Guidelines

Table 1 provides information and guidelines about the functions, ratings, and requirements for the FEC input and output terminals; and references guidelines for determining proper wire sizes and cable lengths.

In addition to the wiring guidelines in Table 1, observe these guidelines when wiring FEC inputs and outputs:

- Run **all** low-voltage wiring and cables separate from high-voltage wiring.

- All input and output cables, regardless of wire size or number of wires, should consist of stranded, insulated, and twisted copper wires.
- Shielded cable is not required for input or output cables.
- Shielded cable is recommended for input and output cables that are exposed to high electromagnetic or radio frequency noise.
- Inputs/outputs with cables less than 30 m (100 ft) typically do not require an offset in the software setup. Cable runs over 30 m (100 ft) may require an offset in the input/output software setup.

Table 1: I/O Terminal Blocks, Functions, Ratings, Requirements, and Cables (Part 1 of 2)

Terminal Block Label	Terminal Labels	Function, Ratings, and Requirements	Determine Wire Size and Maximum Cable Length ¹
UNIVERSAL (Inputs)	+15 V	15 VDC Power Source for active (3-wire) input devices connected to the Universal IN _n terminals. Provides 100 mA total current.	Same as (Universal) IN _n . Note: Use 3-wire cable for devices that source power from the +15 V terminal.
	IN _n	Analog Input - Voltage Mode (0-10 VDC) 10 VDC maximum input voltage Internal 75k ohm Pulldown	See Guideline A in Table 2.
		Analog Input - Current Mode (4-20 mA) Internal 100 ohm load Impedance A current loop fail-safe jumper can be positioned to maintain a closed 4-20 mA current loop even when power to the controller is interrupted or off. See Universal Input Current Loop Jumpers .	See Guideline B in Table 2.
		Analog Input - Resistive Mode (0-600k ohm) Internal 12 V, 15k ohm pull up Qualified Sensors: 0-2k potentiometer, RTD (1k Nickel [Johnson Controls® sensor], 1k Platinum, and A99B Silicon Temperature Sensor) Negative Temperature Coefficient (NTC) Sensor (10k Type L, 10k JCI Type II, 2.252k Type II)	See Guideline A in Table 2.
		Binary Input - Dry Contact Maintained Mode 1 second minimum pulse width Internal 12 V, 15k ohm pull up	See Guideline A in Table 2.
	ICOM _n	Universal Input Common for all Universal IN terminals Note: All Universal ICOM _n terminals share a common, which is isolated from all other commons.	Same as (Universal) IN _n .
BINARY (Inputs)	IN _n	Binary Input - Dry Contact Maintained Mode 0.01 second min. pulse width Internal 18 V, 3k ohm pull up	See Guideline A in Table 2.
		Binary Input - Pulse Counter/Accumulator Mode 0.01 second minimum pulse width (50 Hz at 50% duty cycle) Internal 18 V, 3k ohm pull up	
	ICOM _n	Binary Input Common for all Binary Input (IN) terminals Note: All Binary ICOM _n terminals share a common, which is isolated from all other commons, except the Configurable Output (CO) common (OCOM _n) when the CO is defined as an Analog Output.	

Table 1: I/O Terminal Blocks, Functions, Ratings, Requirements, and Cables (Part 2 of 2)

Terminal Block Label	Terminal Labels	Function, Ratings, and Requirements	Determine Wire Size and Maximum Cable Length ¹
BINARY (Outputs) Power Selection Jumper positioned to External (EXT).	OUT_n	Binary Output - 24 VAC Triac (External Power) Connects OUT_n to OCOM_n when activated. External Power Source: 30 VAC maximum output voltage 0.5 A maximum output current 1.3 A at 25% duty cycle Maximum 6 cycles/hour with M9220-BGx-3 40 mA minimum load current	See Guideline C in Table 2.
	OCOM_n	Binary Output Common (for OUT_n terminal) Note: Each Binary Output common terminal (OCOM_n) is isolated from all other commons, including other Binary Output commons.	
BINARY (Outputs) Power Selection Jumper positioned to Internal (INT).	OUT_n	Binary Output - 24 VAC Triac (Internal Power) Sources internal 24 VAC power (24~ HOT)	See Guideline C in Table 2.
	OCOM_n	Binary Output - 24 VAC Triac (Internal Power) Connects OCOM_n to 24~ COM when activated. Internal Power Source: 30 VAC maximum voltage to load 0.5 A maximum output current 1.3 A at 25% duty cycle Maximum 6 cycles/hour with M9220-BGx-3 40 mA minimum load current	
CONFIGURABLE (Outputs)	OUT_n	Analog Output - Voltage Mode (0-10 VDC) 10 VDC maximum output voltage 10 mA maximum output current Requires an external load of 1,000 ohm or more	See Guideline A in Table 2.
		Binary Output 24 VAC Triac Connects OUT to OCOM when activated. External Power Source: 30 VAC maximum voltage to load 0.5 A maximum output current 1.3 A at 25% duty cycle Maximum 6 cycles/hour with M9220-BGx-3 40 mA minimum load current	See Guideline C in Table 2.
	OCOM_n	Analog Output Signal Common: All Configurable Outputs defined as Analog Outputs share a common, which is isolated from all other commons except the Binary Input common. Binary Output Signal Common: All Configurable Outputs (COs) defined as Binary Outputs are isolated from all other commons, including other CO commons.	Same as (Configurable) OUT_n .

1. See Table 2 to determine wire size and cable lengths for cables other than the recommended cables.

Table 2 defines cable length guidelines for the various wire sizes that may be used for input and output wiring.

Table 2: Cable Length Guidelines for Recommended Wire Sizes

Guideline	Wire Size/Gauge and Type	Maximum Cable Length and Type	Assumptions
A	1.5 mm ² (18 AWG) stranded copper	457 m (1,500 ft) twisted wire	100 mV maximum voltage drop Depending on the cable length and the connected input or output device, you may have to define an offset in the setup software for the input or output point.
	0.8 mm (20 AWG) stranded copper	297 m (975 ft) twisted wire	
	0.6 mm (22 AWG) stranded copper	183 m (600 ft) twisted wire	
	N/A (24 AWG) stranded copper	107 m (350 ft) twisted wire	
B	1.5 mm ² (18 AWG) stranded copper	229 m (750 ft) twisted wire	100 mV maximum voltage drop Depending on the cable length and the connected input or output device, you may have to define an offset in the setup software for the input or output point.
	0.8 mm (20 AWG) stranded copper	137 m (450 ft) twisted wire	
	0.6 mm (22 AWG) stranded copper	91 m (300 ft) twisted wire	
	N/A (24 AWG) stranded copper	61 m (200 ft) twisted wire	
C	See Figure 8 to select wire size/gauge. Use stranded copper wire.	See Figure 8 to determine cable length. Use twisted wire cable.	N/A

Maximum Cable Length versus Load Current

Use Figure 8 to estimate the maximum cable length relative to the wire size and the load current (in mA) when wiring inputs and outputs.

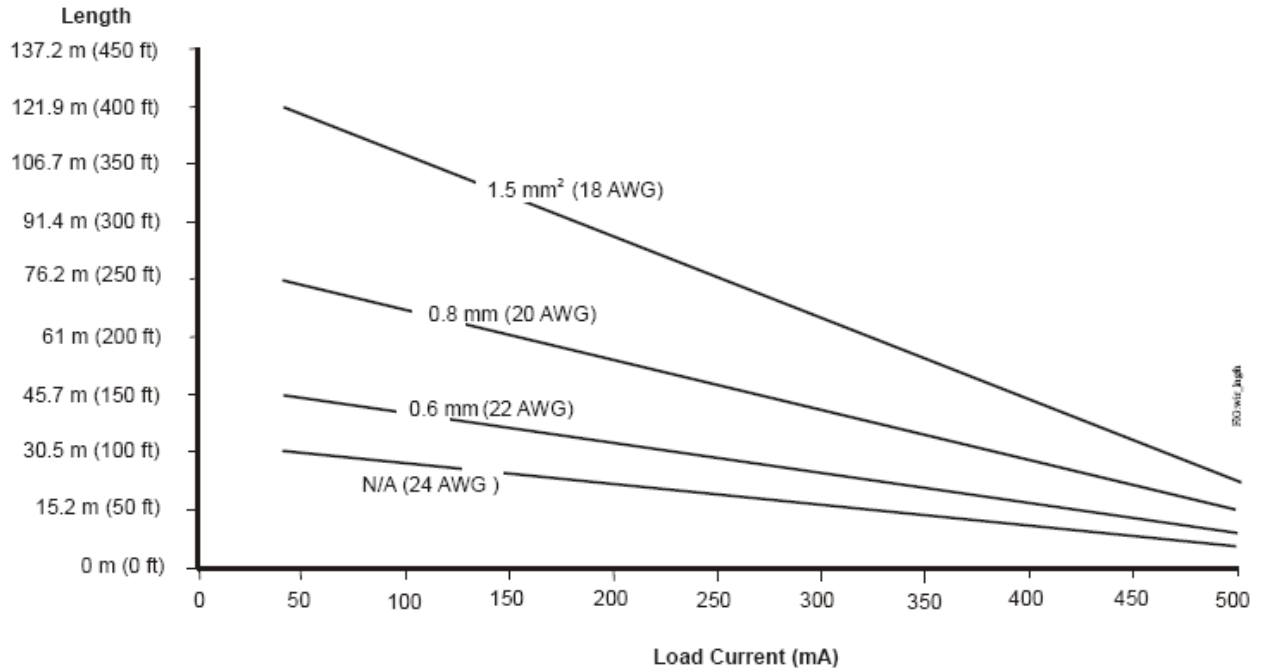

Figure 8: Maximum Wire Length by Current and Wire Size

FC and SA Bus and Supply Power Wiring Guidelines

Table 3 provides information about the functions, ratings, and requirements for the FEC communication bus and supply power terminals; and provides guidelines for wire sizes, cable types, and cable lengths when wiring the FEC communication buses and supply power.

In addition to the guidelines in Table 3, observe these guidelines when wiring the SA/FC Buses and supply power:

- Run **all** low-voltage wiring and cables separate from high-voltage wiring.
- All FC and SA Bus cables, regardless of wire size, should be twisted, insulated, stranded copper wire.
- Shielded cable is strongly recommended for all FC and SA Bus cables.
- Refer to the *MS/TP Communications Bus Technical Bulletin (LIT-12011034)* for detailed information regarding wire size and cable length requirements for the FC and SA buses.

Table 3: Communication Bus and Supply Power Terminal Blocks, Functions, Ratings, Requirements, and Cables

Terminal Block/Port Label	Terminal Labels	Function, Electrical Ratings/Requirements	Recommended Cable Type ¹
FC BUS ²	+ -	FC Bus Communications	0.6 mm (22 AWG) stranded, 3-wire twisted, shielded cable recommended
	COM	Signal Reference (Common) for bus communications	
	SHLD	Isolated terminal (optional shield drain connection)	
FC BUS ² (Port)		RJ-12 6-Position Modular Connector provides: FC Bus Communications FC Bus Signal Reference and 15 VDC Common 15 VDC Power for Wireless Commissioning Converter or ZFR1811 Wireless Router.	Wireless Commissioning Converter retractable cable or 24 AWG 3-pair CAT 3 Cable <30.5 m (100 ft)
SA BUS ²	+ -	SA Bus Communications	0.6 mm (22 AWG) stranded, 4-wire (2 twisted-pairs), shielded cable recommended Note: The + and - wires are one twisted pair and the COM and SA PWR are the second twisted pair of wires.
	COM	SA Bus Signal Reference and 15 VDC Common	
	SA PWR	15 VDC Supply Power for Devices on the SA Bus (Maximum total current draw for SA Bus is 240 mA.)	
SENSOR ² (SA Bus Port)		RJ-12 6-Position Modular Connector provides: SA Bus Communications SA Bus Signal Reference and 15 VDC Common 15 VDC Power for devices on the SA Bus and Wireless Commissioning Converter.	24 AWG 3-pair CAT 3 Cable <30.5 m (100 ft)
24~	HOT	24 VAC Power Supply - Hot Supplies 20-30 VAC (Nominal 24 VAC)	0.8 mm to 1.5 mm ² (20 to 16 AWG) 2-wire
	COM	24 VAC Power Supply Common (Isolated from all other Common terminals on controller)	

1. See Table 2 to determine wire size and cable lengths for cables other than the recommended cables.
2. The SA Bus and FC Bus wiring recommendations in this table are for MS/TP bus communications at 38.4k baud. For more information, refer to the *MS/TP Communications Bus Technical Bulletin (LIT-12011034)*.

Setup and Adjustments

Setting the Device Address

Metasys field controllers are master devices on BACnet MS/TP (SA or FC) buses. Before operating field controllers on a bus, you **must** set a valid and unique device address for each controller on the bus.

You set a field controller's device address by setting the positions of the switches on the Device Address DIP switch block at the top of the controller (Figure 3). Device addresses 4 through 127 are the valid addresses for these controllers.

The DIP switch block (Figure 9) has eight switches numbered 128, 64, 32, 16, 8, 4, 2, and 1. Switches 64 through 1 are device address switches. Switch 128 is a mode switch that enables a field controller to operate on a ZFR1800 Series Wireless Field Bus. Switch 128 must be set to off for all hard-wired SA and FC Bus applications. Set switch 128 to ON for wireless FC Bus applications **only**.



Figure 9: Device Address Switches Set to 21

Note: Metasys field controllers ship with switch 128 ON and the remaining address switches off rendering the controllers wired slave devices, which do not operate on MS/TP buses, but do not interfere with bus operation. Set a valid and unique device address on the field controller before applying power to the controller on the bus.

To set the device addresses on Metasys field controllers:

1. Set all of the switches on the field controller's device address DIP switch block (128 through 1) to off.
2. Set one or more of the seven address switches (64 through 1) to ON, so that the sum of the switch numbers set to ON equals the intended device address. See Table 4 for valid field controller addresses.

Set the highest number switch that is less than or equal to the intended device address to ON. Then continue setting lower numbered switches until the total equals the intended address. For example, if the intended device address is 21, set switch 16 to ON first, then set switch 4 ON, followed by switch 1 ($16+4+1=21$). See Figure 9.

3. Set switch 128 to ON only for controllers on a ZFR1800 Series Wireless Field Bus application. For all hard-wired SA and FC Bus applications, ensure that switch 128 is set to off.

Note: Do not connect a field controller with switch 128 set to ON to an active (hard-wired) SA or FC Bus. When a controller with switch 128 set to ON and a device address from 4 to 127 is connected to a wired field bus, the entire field bus is rendered inoperable until the controller is disconnected or switch 128 is set to off.

Refer to the *ZFR1800 Series Wireless Field Bus System Technical Bulletin (LIT-12011295)* for more information on device addresses in wireless applications.

4. Set a unique and sequential device address for each of the field controllers connected on the SA or FC Bus starting with device address 4.

To ensure the best bus performance, set sequential device addresses with no gaps in the device address range (4, 5, 6, 7, 8, 9, and so on). The field controllers do not need to be physically connected on the bus in their numerical device address order.

5. Write each field controller's device address on the white label below the DIP switch block on the controller's cover.

Refer to the *MS/TP Communications Bus Technical Bulletin (LIT-12011034)* for more information on field controller device addresses and how to set them on MS/TP buses.

Table 4 shows and describes the valid FC Bus and SA Bus device addresses for Johnson Controls® MS/TP communications bus applications.

Table 4: SA/FC Bus Device Address Descriptions

Device Address	Address Description
0 (Switch 128 Off)	Reserved for FC Bus Supervisory Controller (not valid for field controllers).
1 to 3 (Switch 128 Off)	Reserved for peripheral devices (not valid for field controllers).
4 to 127 (Switch 128 Off)	Valid for MS/TP Master field controllers on a hard-wired SA Bus or FC Bus.
0 to 3 (Switch 128 ON)	Reserved addresses for wired slave devices (not valid for field controllers). Note: Metasys controllers ship with 128 ON and the remaining address switches off, rendering the controllers wired slave devices, which do not operate on Metasys field buses.
4 to 127 (Switch 128 ON)	Valid for MS/TP Master field controllers on wireless FC Buses only . Note: Do not connect a Metasys controller with these device addresses to an active wired SA or FC Bus. When a controller with one of these device address is connected to a wired field bus, the field bus is rendered inoperable until the controller is disconnected or switch 128 is set to off.

Removing the FEC Housing Cover

IMPORTANT: Disconnect all power sources to the controller before removing cover and changing the position of any jumper or the EOL switch on the controller. Failure to disconnect power before changing a jumper or EOL switch position can result in damage to the controller and void any warranties.

IMPORTANT: Electrostatic discharge can damage controller components. Use proper electrostatic discharge precautions during installation, setup, and servicing to avoid damaging the controller.

The controller cover is held in place by four plastic latches that extend from the base and snap into slots on the inside of the housing cover. To remove the controller cover:

1. Place your fingernails under the two cover lift tabs on the sides of the housing cover (Figure 3) and gently pry the top of the cover away from the base to release the cover from the two upper latches.
2. Pivot the top of the cover further to release it from the lower two latches.

Replace the cover by placing it squarely over the base, and then gently and evenly push the cover on to the latches until they snap into the latched position.

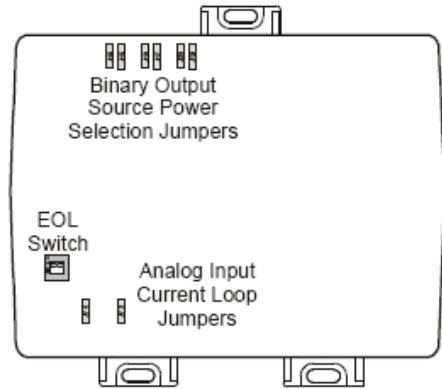

Figure 10: FEC16 with Cover Removed Showing Jumper and EOL Switch Positions

Setting the EOL Switch

Each field controller has an End-of-Line (EOL) switch, which, when set to ON/up, sets the field controller as a terminating device on the bus. See Figure 3 or Figure 10 for the EOL switch location on the field controller. The default EOL switch position is off/down.

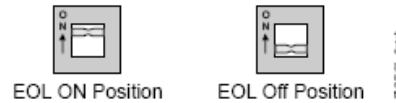

Figure 11: EOL Switch Positions

To set the EOL switch on a field controller:

1. Determine the physical location of the field controller on the SA or FC Bus.
2. Determine if the field controller must be set as a terminating device on the bus.
Note: The EOL termination rules for SA Buses and FC Buses are different. Refer to the *MS/TP Communications Bus Technical Bulletin, (LIT-12011034)* for detailed information regarding EOL termination rules and EOL switch settings on SA and FC Buses.
3. If the field controller is a terminating device on the SA Bus or FC Bus, set the EOL switch to ON. If the field controller is not a terminating device on the bus, set the EOL switch to off.

When a field controller is connected to power with its EOL switch set to ON, the amber EOL Light-Emitting Diode (LED) on the controller cover is lit.

Setting the Input and Output Jumpers

Binary Output Source Power Selection Jumpers



CAUTION: Risk of Electric Shock.
Disconnect supply power to the FEC16 controller before attempting to adjust the Binary Output Source Power Selection Jumpers. Failure to disconnect the supply power may result in electric shock.

IMPORTANT: Do not connect an external power source to a Binary Output (BO) when the BO power source jumper is in the internal power (INT) position. Connecting external power to a BO that sources internal power can damage the controller and void any warranties.

The BO source power selection jumpers determine whether a BO provides internal power (sourced from the FEC) to the output load (INT position) or requires an external power source (EXT position) for the output load. Figure 12 shows an example of an FEC16 controller BOs and the associated power selection jumpers to the right of the BOs terminal block.

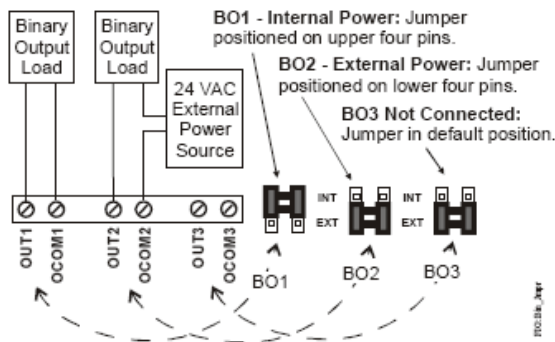

Figure 12: Example Binary Outputs and the Associated Source Power Jumper Positions

Universal Input Current Loop Jumpers

The Universal Input (UI) current loop fail-safe jumpers are on the circuit board under the housing cover near the UI terminals (Figure 10). When a UI is defined (in the system software) as a 4-20 mA analog input and the UI's current loop jumper is in the (default) Disabled position (Figure 13), the 4-20 mA current loop circuit opens whenever power to the FEC is interrupted or off.

Setting the current loop jumper to the Enabled position (Figure 13) connects an internal 100 ohm resistor across the UI terminals, which maintains the 4-20 mA current loop circuit even when power to the FEC is interrupted or off.

IMPORTANT: Current Loop jumpers must be in the (default) Disabled position for all UIs that are **not** set up to operate as 4-20 mA analog inputs.

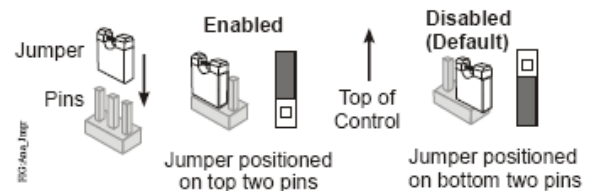

Figure 13: Current Loop Jumper Positions

Table 5 identifies the current loop jumpers associated with each UI on the FEC16 controller.

Table 5: FEC16 UI Inputs and Jumper Labels

Universal Input Label	Jumper Label on Circuit Board
IN1	J74
IN2	J73

Commissioning

Commission the FEC with the Metasys Controller Tool (software), either via the Bluetooth® Wireless Commissioning Converter, ZigBee™ wireless dongle, or in passthrough mode when connected to an NAE or NCE. Refer to *Controller Tool Help (LIT-12011147)*.

Refer to the *DIS1710 Local Controller Display Technical Bulletin (LIT-12011270)* for information on connecting a DIS1710 display.

Troubleshooting

Observe the LEDs on the front of the controller and see Table 6 to troubleshoot the controller.

To troubleshoot the integral FEC display, refer to the *DIS1710 Local Controller Display Technical Bulletin (LIT-12011270)*.

Table 6: Status LEDs and Description of LED States

LED Label	LED Color	Normal State	Descriptions of LED States
POWER	Green	On Steady	Off Steady = No Supply Power or the controller's polyswitch/resettable fuse is open. Check Output wiring for short circuits and cycle power to controller. On Steady = Power Connected
FAULT	Red	Off Steady	Off Steady = No Faults On Steady = Device Fault; no application loaded; Main Code download required, if controller is in Boot mode, or a firmware mismatch exists between the FEC and the ZFR1811 Wireless Field Bus Router. Blink - 2 Hz = Download or Startup in progress, not ready for normal operation Blink Rapidly - 5 Hz = One or more defined SA Bus device is offline. Check SA Bus devices for problems, including low batteries on wireless sensor.
SA BUS	Green	Blink - 2 Hz	Blink - 2 Hz = Data Transmission (normal communication) Off Steady = No Data Transmission (N/A - auto baud not supported) On Steady = Communication lost, waiting to join communication ring
FC BUS	Green	Blink - 2 Hz	Blink - 2 Hz = Data Transmission (normal communication) Off Steady = No Data Transmission (auto baud in progress) On Steady = Communication lost, waiting to join communication ring
EOL	Amber	Off (Except on terminating devices)	On Steady = EOL switch in ON position Off Steady = EOL switch in Off position

Repair Information

If the FEC16 controller fails to operate within its specifications, replace the unit. For a replacement controller, contact the nearest Johnson Controls representative.

Accessories

See Table 7 to order accessories.

Table 7: FEC16 Controller Accessories Ordering Information

Product Code Number	Description
MS-BTCVT-1	Wireless Commissioning Converter, with Bluetooth® Technology
MS-DIS1710-0	Local Controller Display (for use with MS-FEC1611 model only)
MS-ZFR1811-0	Wireless Field Bus Router for wireless FEC applications
TP-2420	Transformer, 120 VAC Primary to 24 VAC secondary, 20 VA, Wall Plug
Y65T31-0 ¹	Transformer, 120/208/240 VAC Primary to 24 VAC Secondary, 40 VA, Foot Mount, 8 in. Primary Leads and Secondary Screw Terminals, Class 2
AS-XFR050-0	Power transformer (Class 2, 24 VAC, 50 VA maximum output), no enclosure
AP-TBK4SA-0	Replacement MS/TP SA Bus Terminal, 4-Position, Brown, Bulk Pack
AP-TBK4FC-0	Replacement MS/TP FC Bus Terminal, 4-Position, Blue, Bulk Pack
AP-TBK3PW-0	Replacement Power Terminal, 3-Position Connector, Gray, Bulk Pack

1. Additional Y60 Series transformers are also available.

Technical Specifications

FEC16 Extended Temperature Controller (Part 1 of 2)

Product Code Numbers	MS-FEC1611-0ET Field Equipment Controller
Supply Voltage	24 VAC (nominal, 20 VAC minimum/30 VAC maximum), 50/60 Hz, power supply Class 2 (North America), Safety Extra-Low Voltage (SELV) (Europe)
Ambient Conditions	Operating: -40 to 70°C (-40 to 158°F); 10 to 90% RH noncondensing Storage: -40 to 80°C (-40 to 176°F); 5 to 95% RH noncondensing
Controller Addressing	DIP switch set; valid field controller device addresses 4–127 (Device addresses 0–3 and 128–255 are reserved and not valid field controller addresses.)
Communications Bus	BACnet® MS/TP, RS-485: 3-wire FC Bus between the supervisory controller and field controllers 4-wire SA Bus between field controller, network sensors and other sensor/actuator devices, includes a lead to source 15 VDC supply power (from field controller) to bus devices.
Processor	H8SX/166xR Renesas® 32-bit microcontroller
Memory	1 MB Flash Memory and 512 KB Random Access Memory (RAM)
Input and Output Capabilities	2 - Universal Inputs: Defined as 0-10 VDC, 4-20 mA, 0-600k ohm, or Binary Dry Contact 1 - Binary Inputs: Defined as Dry Contact Maintained or Pulse Counter/Accumulator Mode 3 - Binary Outputs: Defined as 24 VAC Triac (selectable internal or external source power) 4 - Configurable Outputs: Defined as 0-10 VDC or 24 VAC Triac BO
Analog Input/Analog Output Resolution and Accuracy	Input: 16-bit resolution Output: 16-bit resolution, ±200 mV accuracy in 0-10 VDC applications
Terminations	Input/Output: Fixed Screw Terminal Blocks FC Bus, SA Bus, and Supply Power: 3-Wire and 4-Wire Pluggable Screw Terminal Blocks FC Bus and SA Bus: RJ-12 6-Pin Modular Jacks
Mounting	Horizontal on single 35 mm DIN rail mount (preferred), or screw mount on flat surface with three integral mounting clips on controller
Housing	Enclosure material: ABS and polycarbonate UL94 5VB; Self-extinguishing, Plenum Rated Protection Class: IP20 (IEC529)
Dimensions (Height x Width x Depth)	150 x 164 x 53 mm (5-7/8 x 6-7/16 x 2-1/8 in.) including terminals and mounting clips Note: Mounting space requires an additional 50 mm (2 in.) space on top, bottom and front face of controller for easy cover removal, ventilation and wire terminations.

FEC16 Extended Temperature Controller (Part 2 of 2)

Weight	0.4 kg (0.9 lb)
	United States: UL Listed, File E107041, CCN PAZX, UL 916, Energy Management Equipment FCC Compliant to CFR47, Part 15, Subpart B, Class A
	Canada: UL Listed, File E107041, CCN PAZX7, CAN/CSA C22.2 No. 205, Signal Equipment Industry Canada Compliant, ICES-003
	Europe: CE Mark – Johnson Controls, Inc. declares that this product is in compliance with the essential requirements and other relevant provisions of the EMC Directive 2004/108/EC.
	Australia and New Zealand: C-Tick Mark, Australia/NZ Emissions Compliant
	BACnet International: BACnet Testing Laboratories™ (BTL) 135-2004 Listed BACnet Application Specific Controller (B-ASC)

The performance specifications are nominal and conform to acceptable industry standard. For application at conditions beyond these specifications, consult the local Johnson Controls® office. Johnson Controls, Inc. shall not be liable for damages resulting from misapplication or misuse of its products.



Building Efficiency
 507 E. Michigan Street, Milwaukee, WI 53202

Metasys® and Johnson Controls® are registered trademarks of Johnson Controls, Inc. All other marks herein are the marks of their respective owners. © 2013 Johnson Controls, Inc.